

Overview

Featuring 17 million hours on more than 30 applications since its introduction in 1975, the M601 series turboprop engine has a proven record of durability, reliability and ease of maintenance. Derived from this dependable platform, the H80 is bringing advanced power to the turboprop landscape.

GE is incorporating sophisticated technologies into the H80 to elevate it to even higher levels of performance. Modern 3D aero design and advanced materials have been integrated into the compressor stages and turbine of the engine's gas generator. A blisk design, replacing individually bladed compressor disks, has also been incorporated in the axial compressor stages. Materials with higher temperature capabilities have been introduced into the turbine nozzle guide vanes of both the gas generator and power turbine. These technologies deliver more shaft horsepower, improve engine fuel efficiency and provide increased temperature margin, significantly enhancing hot-day takeoff performance and high-altitude cruise speeds.

Standard Engine Hardware

- Fuel control unit
- Fuel pump
- Ignition unit
- Oil filter impeding by-pass signaller
- Gas generator speed transmitter
- Prop speed transmitter
- ITT transmitter
- Torquemeter
- Oil temperature transmitter
- Engine mount body

Accessories

- Starter/generator
- Propeller speed governor
- Propeller speed limiter
- Engine limiting unit
- Beta signaller switch
- Fuel filter with by-pass signaller

H80 Turboprop Engine

Advancing a legacy of reliable power for turboprop aircraft

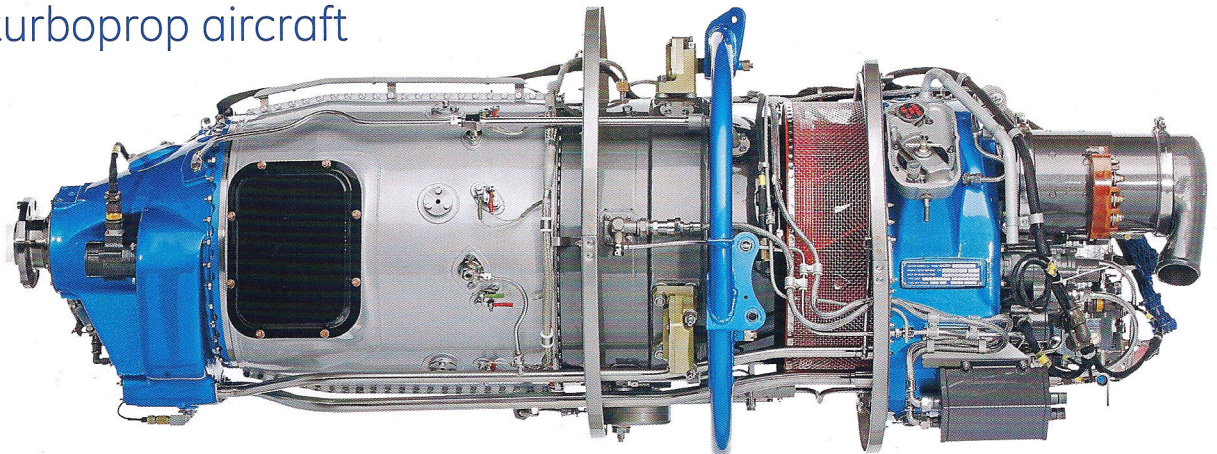

North America
 Matt Gerus
 T 513.552.2985
 C 513.658.5096
 matthew.gerus@ge.com

Europe
 Michal Ptacnik
 T +420 222 538 111
 C +420 602 643 547
 michal.ptacnik@ge.com

Czech Republic
 Beranových 65
 199 02 Praha 9

geaviation.com

Specifications subject to change without notice.

© 2009 General Electric Company
 All Rights Reserved.

Specifications

Sea level - standard day	
Power Output	shp 800 eshp 846
ESFC	0.585
RPM	gas gen (98.4%) - 36,059 shaft output - 2,080
Propeller Rotation	ccw from rear
Weight (Basic Dry Mass)	390 lbs
Pressure Ratio	6.7
Airflow	8.2 lb/s
Fuel	Jet A, Jet A-1
Oil	Mil-L 23699C
Electrical	27 VDC, 200 amp
Bleed Air	2.4% (max)
TBO	Hours - 3,600 Cycles - 6,600

Performance

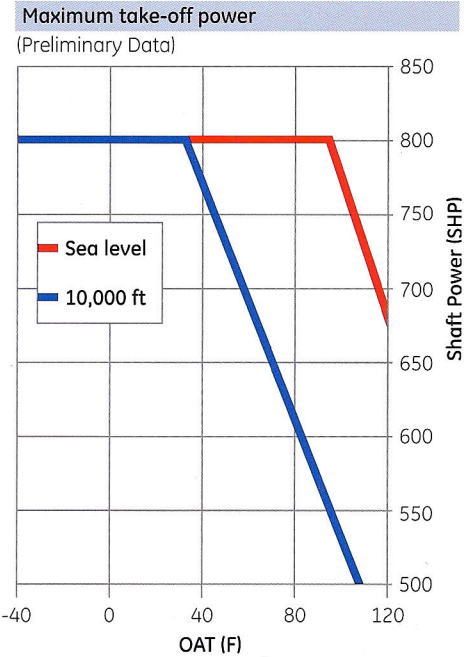

Dimensions

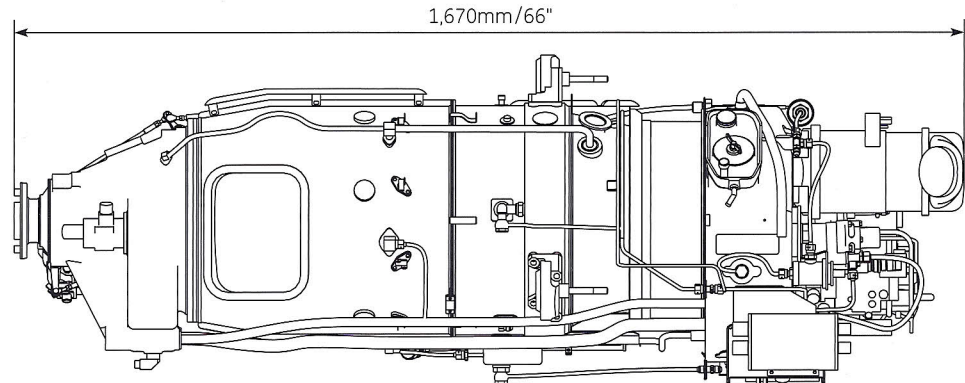
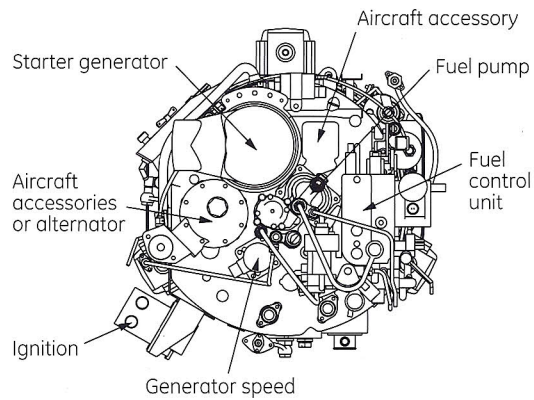
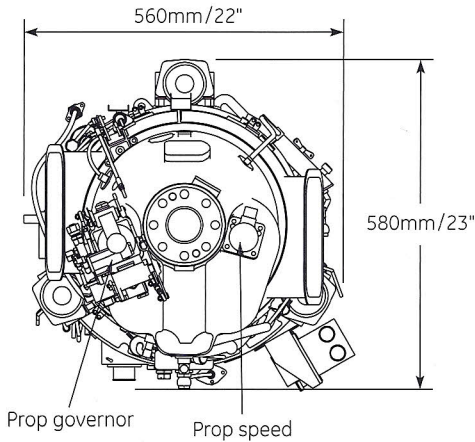

imagination at work